



CS1010 Long Range Leak Sensor

User Guide

Long-range, low-power water leak sensor supporting LoRaWAN or Coralink wireless protocols. Ideal for applications in smart-building, home automation, metering, and logistics.



Version: 1.1
February 2022



Codepoint
Technologies, Inc.
www.codepoint.xyz

Contents

Getting Started.....	3
What's In the Box.....	3
Attaching to the Network.....	4
User Interface	4
Set Button.....	4
Status Indicators	6
About LoRaWAN	6
Terminology.....	6
Installation.....	7
Suggested Applications	7
Event Notifications and Reports.....	8
Reset Notifications.....	8
Firmware Version.....	8
Replacing the Batteries.....	9
Configuration and Integration.....	11
Specifications.....	12
Ordering Information	13
Communication Options.....	13
Product SKU.....	13
FCC Statement.....	15

Getting Started

The CS1010 is a long-range, low-power water leak sensor supporting LoRaWAN or Coralink wireless protocols. The sensor supports configurable real-time notifications and/or regular reported statistics.

Deploy the sensor in hard-to-reach places: under water tanks, basements, bathrooms, attics. The base unit detects the presence water with probes on top and bottom of the device. Place the sensor anywhere there is a substantial risk of damage due to leaks or flooding.

What's In the Box

The CS1010 leak-sensor package includes the following:

- ◆ Leak Sensor
- ◆ LoRa Identity Information

The sensor is self-contained and is watertight. Once activated, the sensor can be placed in areas where potential leaks or flooding are a concern. See *Installation* for details and to learn more about proper placement.

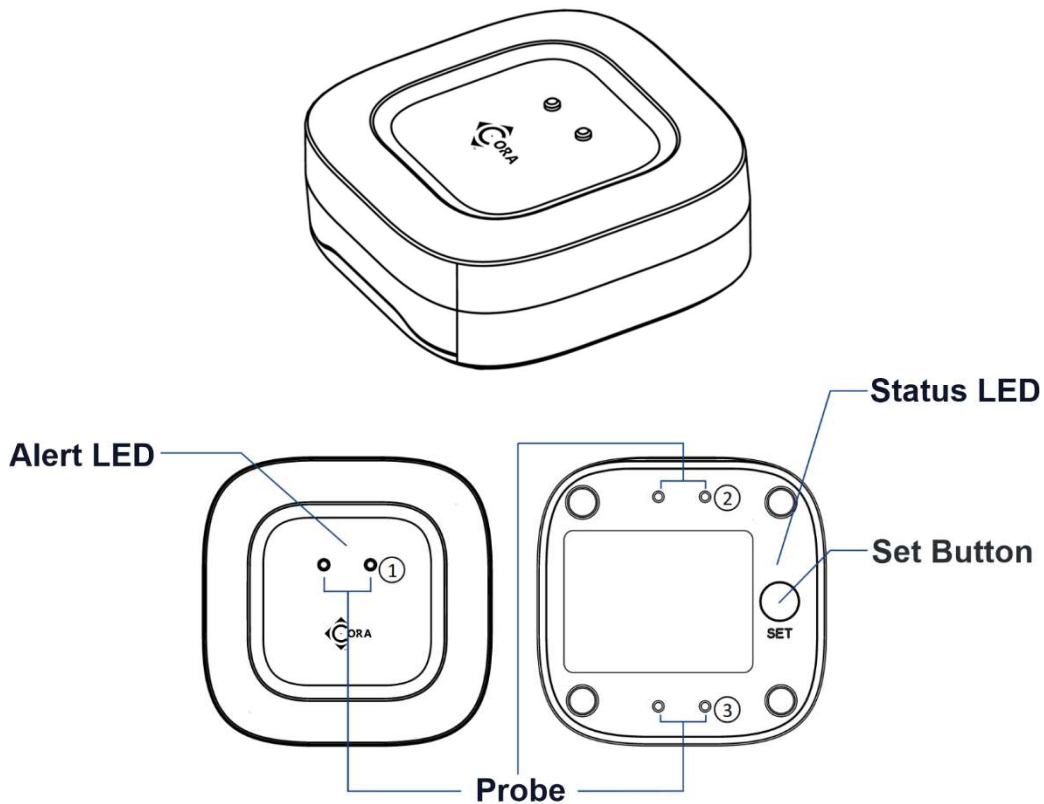

Figure 1 – CS1010 Leak Sensor

Attaching to the Network

Once the device is removed from the packaging, it can be activated by pressing the set button.

The device will activate, blinking orange four times and begin issuing join requests. The LED status indicators is shown in the figure below.



Figure 2 – CS1010 LED Status Indicators

Periodically, the CS1010 will blink red twice when joining the network. Assuming the device is properly registered on an available network and in range, it should connect. It will blink green four times indicating it has joined.

Once joined, the leak sensor can be tested by placing the device in a wet dish or touching the top sensors with a wet finger. By default, the unit will generate leak detect and clear events to notify the application. Reminders and other configurations options are available.

Note: If the CS1010 has not joined within a few minutes, the LED will stop blinking, though it will continue try to join: ten times in the first hour, then longer intervals over the first week until finally attempting once every 12 hours. This is done to conserve battery power when the network is not available for long periods of time. You may reset the join schedule by performing a Network Reset on the device, see *User Interface*.

To learn more about the capabilities of the CS1010, see *Configuration and Integration*.

User Interface

Set Button

The CS1010 user interface consists of the LED status indicators (Figure 2) and the set button located on the underside of the device. Pressing the button quickly will indicate the current network status discussed previously.

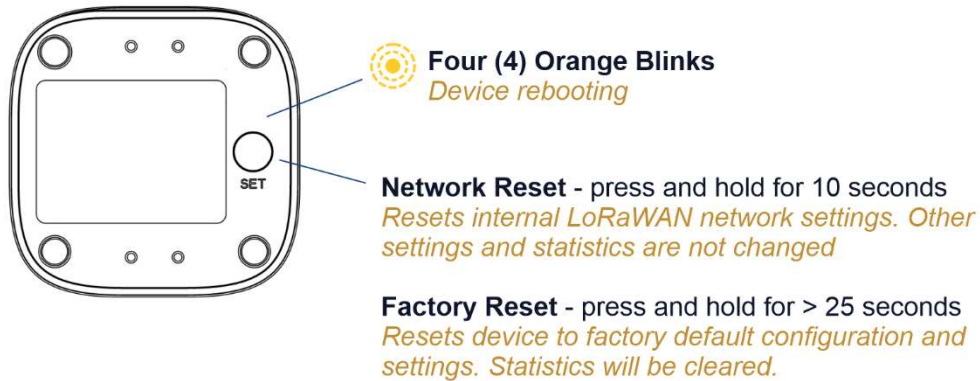

Figure 3 – Performing Network or Factory Reset on the Leak Sensor

Holding the button will perform a network or factory reset:

- ◆ **Network Reset** – Press and hold the SET button for 10 seconds, but less than 25, then release. The device will reset all LoRaWAN Settings, which does not affect device operation or configuration. Following reboot, a reset event uplink (confirmed) will be sent upon rejoining the LoRaWAN network.
- ◆ **Factory Reset** – Press and hold the SET button for > 25 seconds, then release. The device will reset all parameters to factory defaults. Following reboot, a Factory Reset event uplink (confirmed) will be sent upon rejoining the LoRaWAN network.

Status Indicators

A single button press will indicate the network status. The following table summarizes all the LED indicators.

LED	Status
Fast Red Blink Two (2) Times	Not Joined
Fast Green Blink Four (4) Times	Joined
Slow Red Blink Two (2) Times	Joining Network
Slow Green Blink Four (4) Times	Joined Network

Network status blink occurs up to 50 times. Single button press will resume status blink for another 50 cycles.

About LoRaWAN

LoRaWAN is a low-power, secure, wide area (LPWAN) networking protocol designed to wirelessly connect devices to the internet in regional, national, or global networks. To use the CS1010 Leak Sensor, wireless connectivity to an internet connected LoRaWAN gateway is required.

For more information about LoRa and LoRaWAN visit the LoRa Alliance webpage:

<https://lora-alliance.org/>.

Terminology

- ◆ Message sent from the Leak Sensor to the network are referred to as “uplink messages” or “uplinks”.
- ◆ Messages sent to the Leak Sensor from the network are referred to as “downlink messages” or “downlinks”.
- ◆ Both uplink and downlink messages may be of either “confirmed” or “unconfirmed” type. Confirmed messages are guaranteed to be delivered but will consume extra wireless bandwidth and battery life. These mechanisms are analogous to TCP (confirmed) vs UDP (unconfirmed) protocols used for IP networks.
- ◆ Before a device, such as the CS1010 Leak Sensor can transmit messages using LoRaWAN it must go through a “join” process. The Join process involves key-exchange with the cloud-hosted network provider (The Things Network, Helium, etc.) and is defined in the LoRaWAN protocol standard. If connectivity is lost due to RF interference, power loss or other temporary internet outages, the device will need to rejoin the network prior to being able to transmit messages. This process happens automatically but is managed in a battery-efficient manner and may take significant time.

Installation

Place the leak sensor where a leak or flooding may occur.

Suggested Applications

- ◆ Basement Floors
- ◆ Under Laundry Machines
- ◆ Under Dishwashers
- ◆ Under Refrigerators (w/Ice Machines)
- ◆ Near Sump Pumps
- ◆ Under Fish Tanks / Aquariums
- ◆ Inside Hot Tubs*
- ◆ Locations Subject to Freezing Pipes*



**Please refer to device environmental operating range information. Use this device outside at your own risk*

Event Notifications and Reports

The CS1010 Leak Sensor has three event notifications:

- ◆ **Leak Detected** – Sensor has detected a leak (**default enabled**).
- ◆ **Leak Cleared** – Sensor no longer detects a leak (**default enabled**).
- ◆ **Leak Detected Reminder** – Periodic reminder that a leak is ongoing and has not been cleared. This notification is not enabled by default and can be configured by the application.

Additionally, statistics can be enabled to report aggregate sensor event activity:

- ◆ Leak Detect Counter
- ◆ Leak Clear Counter
- ◆ Lifetime Leak Detect Time
- ◆ Lifetime Leak Clear Time
- ◆ Min/Max Leak Detect Duration
- ◆ Min/Max Leak Clear Duration

Statistics are stored in non-volatile memory and will persist through a battery change or dead battery. Both the statistic reporting and alarms can be configured remotely by sending downlink messages.

The sensor has a periodic Heartbeat/ Battery-status message that is sent to maintain LoRaWAN network connectivity and indicate battery status information. The default period for this message is 60 minutes and may be configured between two (2) minutes minimum and 48 hours maximum

Reset Notifications

FACTORY RESET uplink messages will be sent after rebooting.

Firmware Version

The firmware information can be retrieved via sending a downlink command. See *Configuration and Integration* for details.

Replacing the Batteries

A small Philips screwdriver and tweezers are needed to replace the batteries.



Small Philips
Screwdriver



Tweezers



1. TO MAINTAIN THE WATERTIGHT DESIGN OF THE LEAK SENSOR, USE EXTREME CARE AND FOLLOW THE BATTERY REPLACEMENT INSTRUCTIONS CLOSELY.
2. DO NOT MIX OLD AND NEW BATTERIES
3. MAKE SURE THE BOTTOM SHELL AND SEALED RUBBER PADS ARE TIGHTLY SECURED. OTHERWISE, THE ENTRY OF WATER INTO THE SENSOR MAY CAUSE SEVERE DAMAGE.

- 1 Use tweezers to take out the four sealed rubber pads at the base of the device

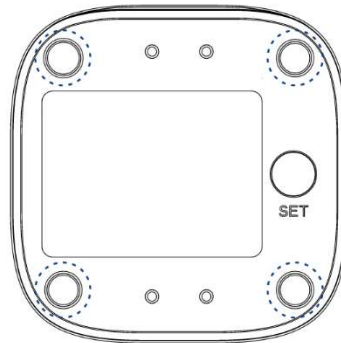

- 2 Use a screwdriver to unscrew the screws at the base of the device and remove the base

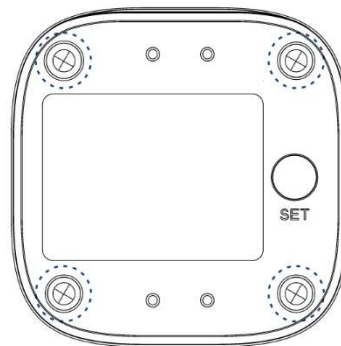

- 3 Remove the two old batteries

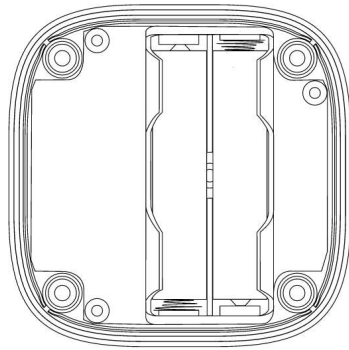

- 4 Install two new AAA batteries

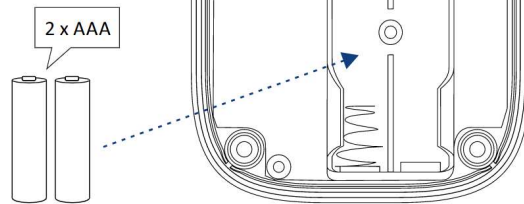

- 5 Close and secure the base by reinstalling and tightening the four screws

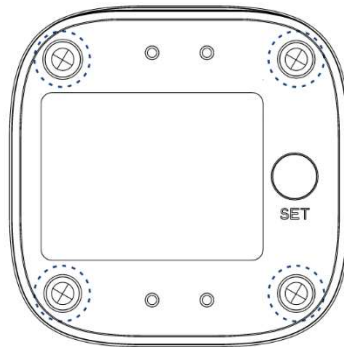

- 6 Reattach the four sealing rubber pads

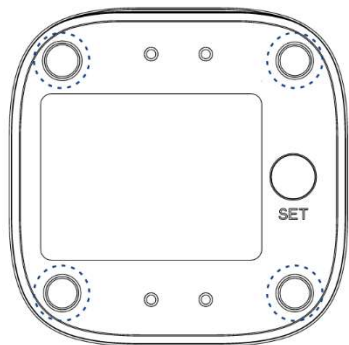

Configuration and Integration

The CS1010 supports the following settings and features, which are configured via downlink messages.

Configuration	Description	Units	Default
Leak Notification Reminder Interval	How often the leak reminder notification is uplinked.	minutes	10
Leak Notification Reminder Count	The maximum count of reminder notifications after the leak is detected.	count	0xFFFF
Heartbeat / Battery Interval	Specifies the heartbeat message uplink interval	minutes	180
Statistics Interval	How often the statistics are uplinked.	minutes	0: disabled
Clear Statistics	Downlink this message to clear the stored statistics	N/A	N/A
LED Mode	<ul style="list-style-type: none"> LED OFF (Stealth Mode) LED ON (Telemetry Only) LED ON (Sensor and Telemetry) 	N/A	LED ON (Sensor and Telemetry)
Notification Confirm / Unconfirmed Setting	If set to true, leak notifications are confirmed uplink messages. Set to false to uplink without confirmation.	N/A	CONFIRMED MESSAGES
Notification Enable	Enable or Disable notifications. If disabled, the sensor operate as a counter / statistic only device.	N/A	enabled
Firmware Version	Downlink this message to retrieve the firmware information	N/A	N/A

For information on decoding and encoding the sensor messages please visit the product page at [Cora CS1010 Leak Sensor - Codepoint Technologies](#).

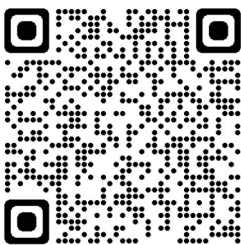

Specifications

- ◆ LoRaWAN v1.03 Class A, Coralink™ Class A device
- ◆ U.S. 923 MHz, E.U. 868 MHz, China 470 MHz, and other frequencies available
- ◆ Color: White
- ◆ Dimensions [L x W x D]: 2.44 x 2.44 x 0.96 inches (62 x 62 x 24.5 mm)
- ◆ Multi-color status LED (underside)
- ◆ LED leak indicator
- ◆ Set button (undersize)
- ◆ Power: 2 AAA batteries (3V DC)
- ◆ **Environmental:**
 - Operating Temperature Range: 32°F – 122°F (0°C – 50°C)
 - Operating Humidity Range: < 95% non-condensing
- ◆ Intended for indoor use only

Ordering Information

Communication Options

Prior to ordering, determine the communication requirements:

- ◆ **Application Protocol:** Untethered XMF or CP-Flex OCM
- ◆ **Network Protocol:** LoRaWAN or Coralink
- ◆ **Operating Region and Frequency:** US915, EU868, CN470 (others available upon request)
- ◆ **Network Provider:** TTN, Helium, Chirp stack, etc.

Product SKU

When placing an order use the following SKU structure to determine the specific version, profile, hardware revision, and packaging needed for the application.

The specification below details the SKU fields and character length.

[id: 6]-[version:2]-[Profile:5]-[Packaging:2]

The fields are defined as follows.

Field name	Character Length	Description
ID	6	Device six (6) character identification code, Available options: CS1010 – Revision A Cora Leak Sensor
Version	2	Device version specification identifying one or key variations that differentiate this version of the component relative to others. Available options: UL – Untethered XMF Application / LoRaWAN protocols CL – Cora OCM / LoRaWAN protocols CC – Cora OCM / Coralink protocols
Profile	5	Profile code specifies a configuration that may be unique for an implementation. Available options: US9HT – U.S. 915 MHz Region supporting Helium, TTN sub-band 2. EU8ST – Europe 868 MHz region standard configuration CN4EZ – China 470 MHz region Easylinkin (Link ware) network configuration Other profiles are available upon request.

Packaging	2	Packaging configuration. This code determines the packaging format for the device. Available standard options: 00 – Standard reseller packaging. Device identification details included. 01 – Solution provider / reseller packaging. Only manufacturing ID provided. Provider receives CSV file with all identifiers to load into their database. 0X – Custom packaging option. Contact Codepoint for further information.
------------------	---	--

Example SKUs:

- ◆ **CS1010-UL-US9HT-00** – Leak sensor for U.S. region, untethered, supporting Helium and TTN sub-band 2.
- ◆ **CS1010-UL-EU8ST-01** – Leak sensor for Europe region, untethered, standard configuration, packaged for solution provider distribution.
- CS1010-CL-US9HT-00** – Leak sensor configured for Cora OCM and CP-Flex cloud stack integration, Supports OCM V2 protocol specifications.

FCC Statement

This equipment has been tested and found to comply with the limits for a Class B digital device, pursuant to part 15 of the FCC Rules. These limits are designed to provide reasonable protection against harmful interference in a residential installation. This equipment generates, uses, and can radiate radio frequency energy and, if not installed and used in accordance with the instructions, may cause harmful interference to radio communications. However, there is no guarantee that interference will not occur in a particular installation. If this equipment does cause harmful interference to radio or television reception, which can be determined by turning the equipment off and on, the user is encouraged to try to correct the interference by one or more of the following measures:

- ◆ Reorient or relocate the receiving antenna
- ◆ Connect the equipment into an outlet on a circuit different from that to which the receiver is connected
- ◆ Increase the separation between the equipment and receiver
- ◆ Consult the dealer or an experienced radio / TV technician for help

- ◆ This device complies with part 15 of the FCC Rules. Operation is subject to the following two conditions:
 1. This device may not cause harmful interference
 2. This device must accept any interference received, including interference that may cause undesired operation.

Any changes or modifications not expressly approved by the party responsible for compliance could void the user's authority to operate the equipment.

Note: The manufacturer is not responsible for any radio or TV interference caused by unauthorized modifications to this equipment. Such modifications could void the user's authority to operate the equipment.

FCC RF radiation exposure statement

This equipment complies with FCC RF radiation exposure limits set forth for an uncontrolled environment. This device and its antenna must not be co-located or operating in conjunction with any other antenna or transmitter. "To comply with FCC RF exposure compliance requirements, this grant is applicable to only Mobile Configurations. The antennas used for this transmitter must be installed to provide a separation distance of at least 20 cm from all persons and must not be co-located or operating in conjunction with any other antenna or transmitter."